

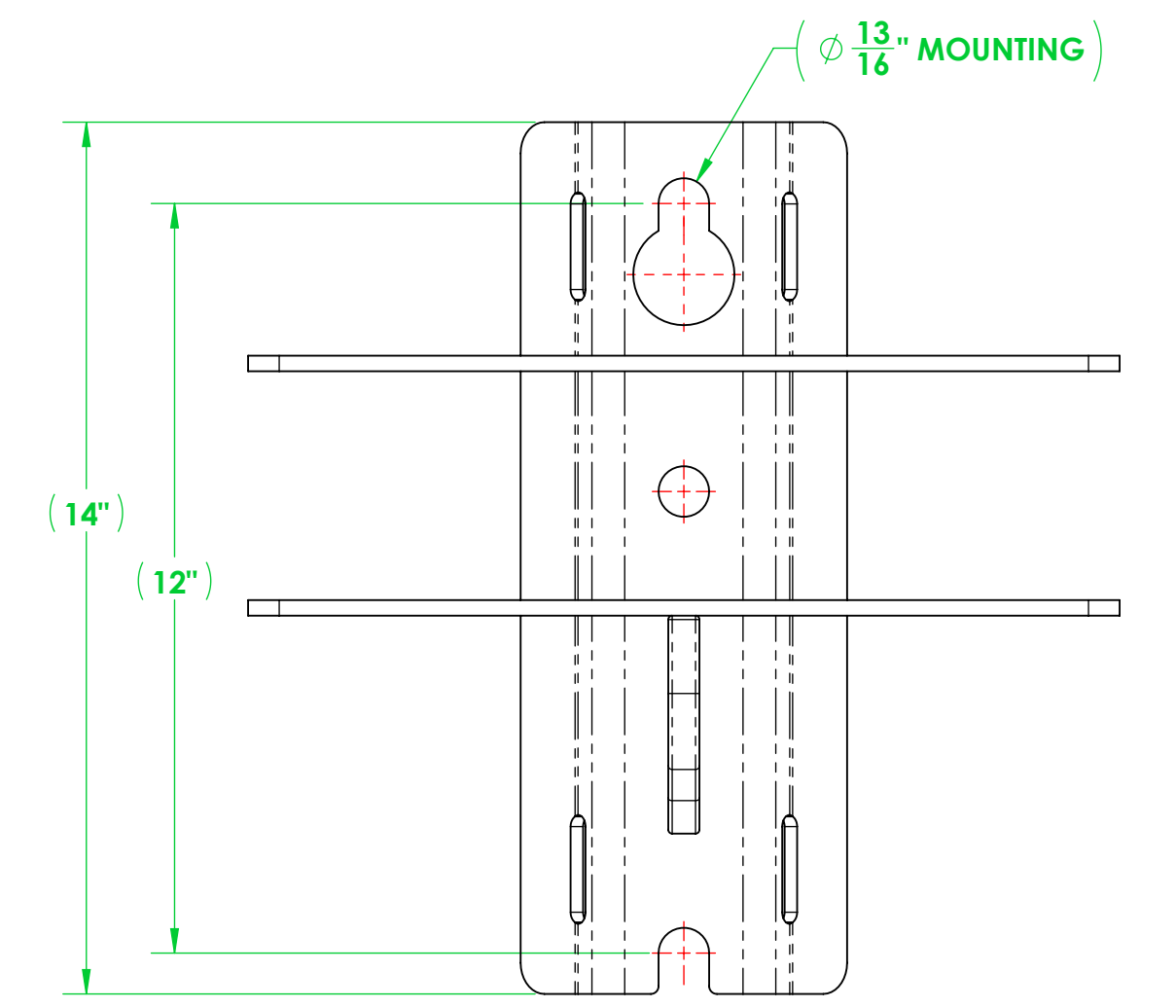

REVISIONS			
REV.	DESCRIPTION	DATE	APPROVED
-	NEW RELEASE	-	-
1	MOUNTING BRACKET WAS FABRICATED NOW PURCHASED. PLATE WASHERS WERE FABRICATED NOW PURCHASED.	4/17/2026	F. BRYANT

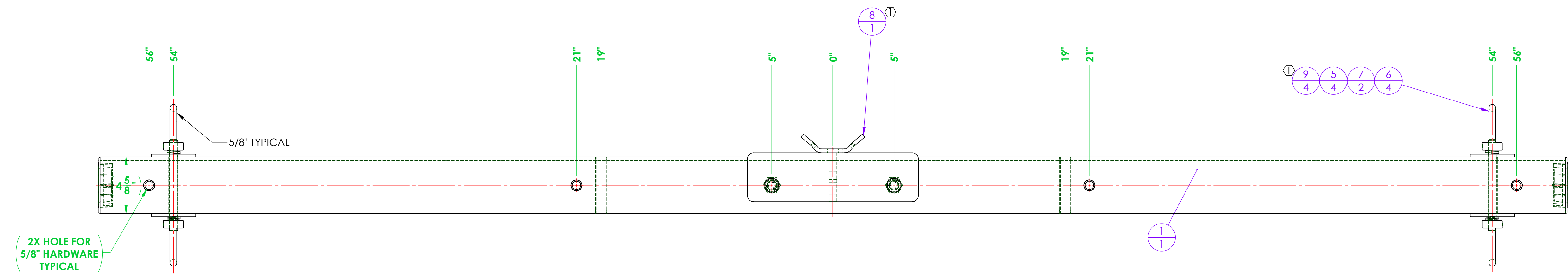

DETAIL A

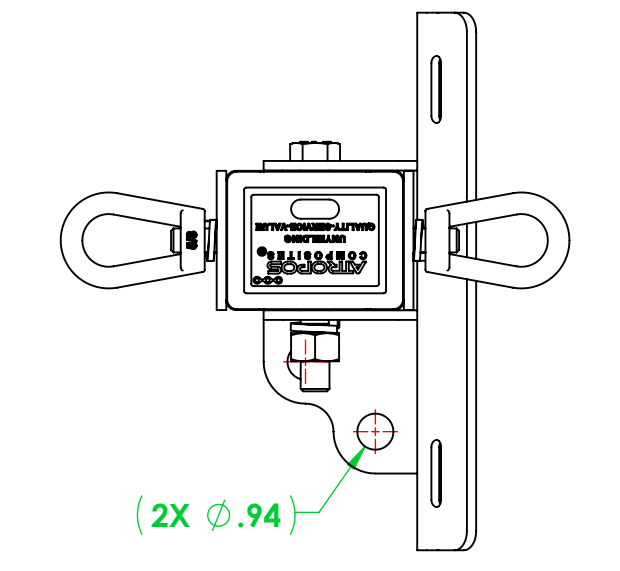
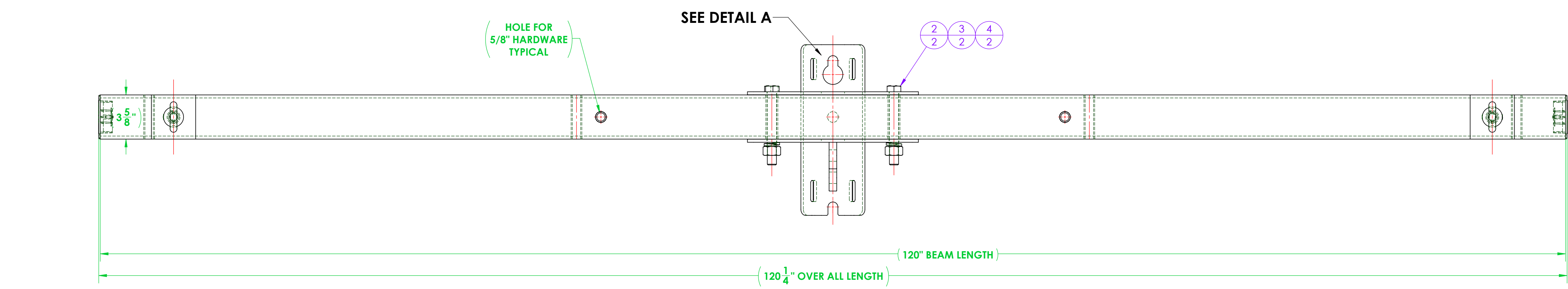

ITEM NO.	PART NUMBER	DESCRIPTION	QTY.
1	3402A120-D312-2911 CA	ASSEMBLY, 3402 DEADEND CROSSARM, 10'	1
2	A616-0020-02	BOLT, HEX, 3/4"-10 X 6.00" LONG, HOT DIPPED GALVANIZED STEEL, 1-1/8" DRIVE	2
3	A616-0042-01	LOCK WASHER, FOR 3/4" SCREW, 0.766" ID, 1.265" OD, 0.188" THICK, HOT-DIPPED GALVANIZED STEEL	2
4	A616-0019-02	EXTREME STRENGTH NUT, HEX, 3/4"-10, 2H, HOT-DIPPED GALVANIZED	2
5	A616-0042-02	LOCK WASHER, FOR 5/8" SCREW, 0.641" ID, 1.073" OD, 0.156" THICK, HOT-DIPPED GALVANIZED STEEL	4
6	A616-0017-02	EYENUT, 5/8"-11, GALVANIZED STEEL	4
7	A711-0044	ALL-THREAD, 5/8"-11 X 7.50" LONG, GALV. STEEL	2
① 8	A700-0044	CROSSARM MOUNTING BRACKET, DEADEND, 3400 SERIES	1
① 9	A700-0049	WASHER, SQUARE, 3.625" X 3.625" X 0.25 THICK WITH 0.66 THRU HOLE	4

GENERAL NOTES	UNLESS OTHERWISE SPECIFIED	NAME	DATE
	DIMENSIONS ARE IN INCHES STANDARD TOLERANCES	DRAWN: F. BRYANT	10/16/2025
	FRACTIONAL: ±1/32	CHECKED:	
	ANGULAR: ±0.5° BEND: ±2°	ENG APPR:	
	TWO PLACE DECIMAL: ±0.03	MFG APPR:	
	THREE PLACE DECIMAL: ±0.005	Q.A.:	
	INTERPRET GEOMETRIC TOLERANCING PER: ANSI Y14.5		
	MATERIAL	PROPRIETARY AND CONFIDENTIAL	
	FINISH	THE INFORMATION CONTAINED IN THIS DRAWING IS THE SOLE PROPERTY OF VETLURIO. ANY REPRODUCTION IN PART OR AS A WHOLE WITHOUT THE WRITTEN PERMISSION OF VETLURIO IS PROHIBITED.	
DO NOT SCALE DRAWING		 12208 MISSOURI BOTTOM ROAD, HAZELWOOD, MO 63042 PHONE: 314.714.4001 FAX: 314.895.1943 SALES@LABYRINTH-TECH.COM	
	TITLE:	SIZE	DWG. NO.
	ASSEMBLY, DEADEND, 3402, (2) WIRE, 10FT.	SCALE: 1:8	WEIGHT: 79.45
		REV	1
		D3402A120-D312-2911	
		SHEET 1 OF 1	